



## Eclipse-4000 Advanced FM Audio Transmitter

# USER'S GUIDE

## Eclipse-4000 Features:

- **Transmit any audio format** to all FM receiver within range in stereo.
- **Create your own personal commercial-free radio station** within you home, office or car.
- **Works with PC/MAC computer:** Transmit any audio format from your desktop or notebook computer. No drivers needed.
- **Listen to audio from your computer speakers and transmit audio at the same time** using included port splitter cable adapter.
- **Works with virtually any device:** iPod, MP3 player, CD player, PDA, DVD player, Notebook/Desktop PC/MAC, satellite receiver, TV, etc.
- **Broadcast any audio format:** MP3, MP4, WMA, WAV, AAC, internet streaming audio, internet radio, CD audio, DVD audio, etc.
- **PLL Synthesized:** Digitally tuned for extra stable transmission, no frequency drifting No re-tuning necessary.
- **LCD display:** Indicates - transmit frequency, audio-mode (stereo/mono).
- **User adjustable frequency range:** User adjustable - 205 frequency range from 87.5 to 108MHz.
- **Interchangeable External antenna.** Optional Telescoping antenna or rubber flexible antenna are available.
- **Microphone input option:** Plug in standard 3.5mm stereo plug microphone to transmit voice. **(USE STEREO MICROPHONE ONLY)**
- **Memory function:** Allowing user to save up to two frequency settings for easy recall.
- **Auto Gain Control** – Automatically adjusts input volume level to prevent distortion in FM receiver.

**Please follow your local regulations as to the allowable transmit range for an FM transmitter.**

## Technical Specifications:

- Dimensions: 5.75" (L) X 3.75" (W) X 1" (D)
- Weight: 11.5 ounces
- Case material: Metal (aluminum)
- Transmit Frequencies: 87.5 ~ 108 MHz (205 frequencies)
- Power requirement: 9V ~13.8V (1.0 Amp)
- Operating current: 400~500mA
- Transmit power: 500mW
- Transmit range: up to 1,600 ft. (500 meters)\*
- Frequency response: 20HZ - 15KHZ
- S/N ratio: 70dB
- Input signal: Stereo
- Output transmit signal: Dual mode: MONO / STEREO (user selectable)
- Operating temperature: 0 ~ 45 degrees Celsius (or) 32 ~ 113 degrees Fahrenheit.
- Power source: 100-240V A/C
- Audio processing limiter, Pre-emphasis: (75uS)
- Output antenna connector: BNC
- Buttons: Frequency (+), Frequency(-), Power, Memory 1, Memory 2, Mute, Transmit Mode (stereo/mono)
- Input/output - Jacks/Ports: BNC antenna connector, audio input (stereo 3.5mm), Microphone input (stereo 3.5mm), Power (DC)
- Display and indicators: Frequency, Audio mode (stereo/mono)

## Box Contents:

- **Mobile Black Box Eclipse-4000 FM transmitter**
- **(5 ft.) 3.5mm audio cable**
- **AC power adapter 100-240V**
- **AC power cable**
- **Telescoping antenna (OR) Rubber antenna**

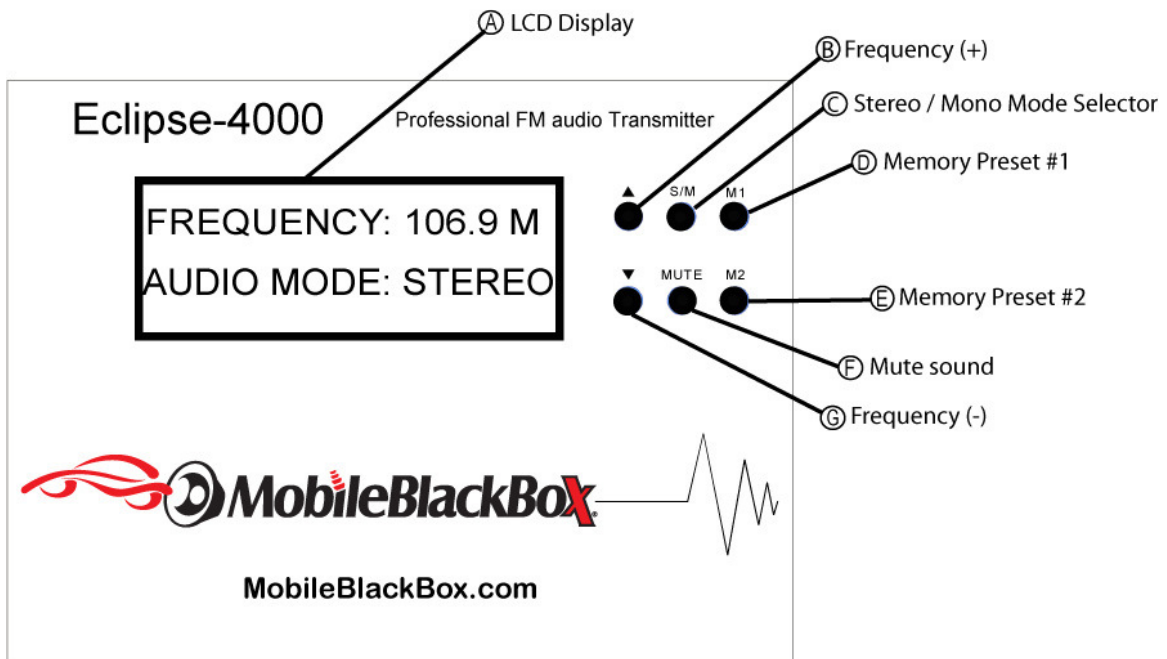

(Front View)

(Side #1 View)

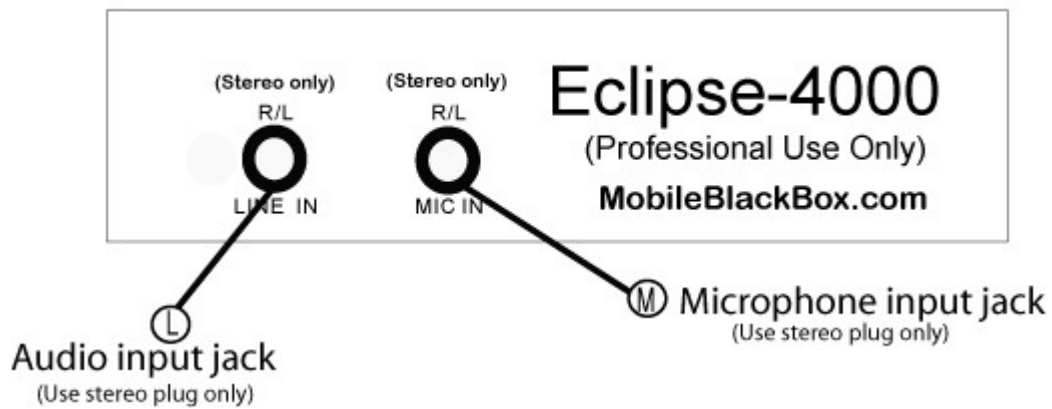

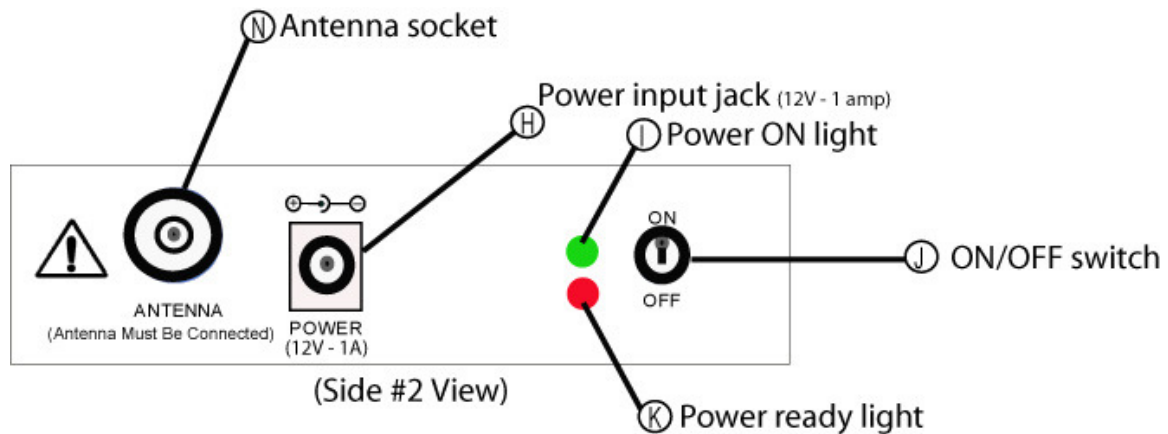

## **Six Common Rules For All Users:**

1. The AC adapter supplied is designed for dry indoor use only. DO NOT use the AC adapter outdoors or in wet conditions.
2. Make sure the supplied antenna is connected at all times when transmitter unit is powered ON. This will prevent damage to your unit.
3. When powering the (Eclipse-4000) transmitter unit OFF; wait 10 minutes before powering unit ON again. This allows the AGC(Auto Gain Control) feature to properly discharge and reset.
4. For best results try to find an open (unused) frequency to transmit on. Do not transmit on occupied commercial radio station frequency; for functional, legal and ethical reasons.
5. Always follow your local regulations regarding the proper use of an FM transmitter.
6. Only use power adapters supplied with your unit. Using other types of power adapters may produce background noise with your transmitted audio and/or could damage your unit.
7. When transmitting from a microphone; only use a stereo plug microphone, using any other type of microphone such as a mono plug microphone will permanently damage your unit, see "Operating Instructions - step #4.

# Operating Instructions:

1. **Connect supplied antenna** to the antenna socket **N**. (*DO NOT operate transmitter without antenna connected, damage may occur to the transmitter unit.*)
2. **Connect power source** to DC power input jack **H**, using the supplied DC power cord/adaptor. Power-Ready RED light **K** will light-up to indicate that power is connected and ready.
3. **Connect audio source** using supplied 3.5mm audio cable. Connect one end to Audio input jack **L**. Connect the other end of the cable to audio output jack (or headphone jack) of the source device *ie. MP3 player, iPod, PC, MAC, PDA, DVD player\*, Satellite receiver\*, TV\*, etc.*

\*Optional RCA/3.5mm convertor cable may be needed to connect to these devices.

4. **Optional – transmitting from a microphone:** You may transmit audio from a microphone by connecting a stereo plug-type microphone to the microphone input jack **M**.

**(DO NOT USE A MONO PLUG-TYPE MICROPHONE, DOING SO WILL CAUSE PERMANENT DAMAGE TO YOUR Eclipse-4000 transmitter UNIT) see illustration below....**

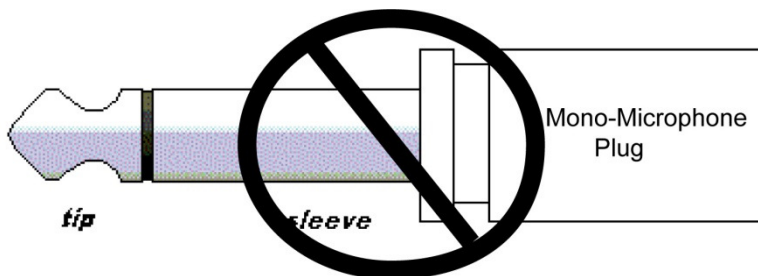

DO NOT USE MONO MICROPHONE

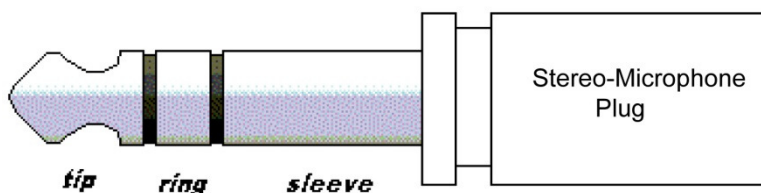

ONLY USE STEREO MICROPHONE

5. **Power unit ON** using power switch **J** LCD will turn ON and the GREEN power ON indicator light **N** will light-up. (LCD display will indicate "SYSTEM INITIAL – MOBILE BLACK BOX"; this should be complete within 5 seconds.)
6. **Set transmitting frequency** using the frequency setting buttons **B** or **G**.  
*(Helpful hint: You should pre-scan your local FM frequencies using an FM radio to find an unused frequency and set the Eclipse-4000 transmitter to this frequency). Helpful hint: You may find optimal or unused FM frequencies to transmit on by visiting [radio-locator.com](http://radio-locator.com)*
7. **Set transmitting mode:** Press **C** button to select **MONO or STEREO** (most users select stereo mode)
8. **Set volume level on the audio source device to about 50% level** (The AGC feature of the Eclipse-4000 will automatically prevent high volume input level thus distortion)
9. **Setting volume level (PC/Mac).** When using the Eclipse-4000 FM transmitter with a PC or Mac computer the volume level will need to be optimized at **all three** different sources: (1) computer's main volume control; (set at 50%) (2) Media player software; (set at 50%) and (3) FM receiver radio; (set at user preferred listening level).
10. **Saving preferred frequency into memory.** The Eclipse-4000 allows the user to save up to two separate frequencies into memory.

To store frequency setting into memory:

**Step 1.** Set your preferred frequency you want saved so it is displayed in the LCD  
*(see instruction #6 above).*

**Step 2.** Choose a memory bank number you wish to save settings to #1 **D** (OR) #2 **E**.

**Step 3.** Press and hold memory bank button chosen in step #2 for three seconds; the LCD will blink one time to indicate the frequency has been saved.

**Step 4.** Your done!! Your preferred frequency has now been saved to your chosen memory bank. To change the settings for a particular memory bank repeat steps 1-3 again.

11. **Optional: MUTE AUDIO FUNCTION:** If you prefer to temporarily mute the audio that is being transmitted; you may press the MUTE button **F** one time; the LCD will indicate that mute function has been activated. No audio will be transmitted when the MUTE function is ON.

# Troubleshooting:

## 1. PROBLEM:

**Transmitting audio volume is too low or no sound is being transmitted:**

### SOLUTION:

Allow unit to remain OFF for 10 minutes; power ON and unit should function normally. When powering the transmitter unit OFF; allow transmitter unit to reset (discharge) the AGC circuit controller (about 10 minutes) before powering ON again.

## 2. PROBLEM:

**Audio is distorted at times when loud sounds are transmitted and/or “SSS” sounds are distorted.**

### SOLUTION:

In some versions of the Eclipse-4000 the Auto Gain Controller threshold is set higher. You will need to decrease the volume level of the source audio.

## 3. PROBLEM:

**Transmit range is lower than the maximum range stated in the specifications:**

### SOLUTION:

The transmit range will vary as per your environment, antenna type, frequency setting, FM receiver sensitivity, etc.

Placing the transmitter (or antenna) on the highest altitude inside or outside of a building with the least amount of obstacles will give you the optimum range. The telescoping antenna option will optimize the transmit range of your unit.

## 4. PROBLEM:

**Transmitted audio seems to have noticeable static noise.**

### SOLUTION:

This is most likely caused by the audio device connected to the Eclipse-4000 or a nearby device.

- If you are using the optional RCA/3.5mm convertor cable try testing the Eclipse-4000 without the cable and with a different audio source device.
- If you are using the Eclipse-4000 with a notebook computer consider using an external USB sound card.
- Test the Eclipse-4000 with a different audio source device and/or within another building/home to help isolate the problem device.
- Make sure the audio level of the source device is set to at least 50%; the Eclipse-4000 can automatically adjust the volume level down to the appropriate level; but it cannot adjust upwards.

**5. PROBLEM:**

**The FM receiver only has static on the frequency set on the transmitter.**

**SOLUTION:**

- Make sure the audio input cable is not connected to the microphone input jack.
- Make sure the Eclipse-4000 is powered ON (GREEN LIGHT on the back of the unit).
- Power OFF the Eclipse-4000 transmitter for 30-60 minutes. Power ON again and test.
- If problem persists contact [support@mobileblackbox.com](mailto:support@mobileblackbox.com)

**6. PROBLEM:**

**Transmitter will not allow transmitting of audio from line-input jack and microphone at the same time.**

**SOLUTION:**

- Eclipse-4000 can only transmit properly from either the line-in audio input jack OR from a microphone input NOT both.

Internet Support: [support@mobileblackbox.com](mailto:support@mobileblackbox.com)

Website: MobileBlackBox.com

\* Transmit range will vary based on environment, frequency, antenna type, etc.  
End user is responsible for proper use and to comply with local regulations.

© 2009 MobileBlackBox.com – Comptech, Inc.